

# Total Tamper CINOART



**TOP  
BARISTA 360**



## PRODUCT MANUAL

## **OVERVIEW Introducción**

---

### **TOTAL TAMPER (CINOART)**

Thank you for choosing the CINOART TOTAL TAMPER.

Please read the following user guide and instructions carefully to ensure the correct use and accurate setup of this machine.

The Cinoart Total tamper will greatly assist the professional barista with workflow speeds while maintaining the consistency of espresso preparation.

Using the Total Tamper greatly improves the flavour yield, consistency, and overall cup quality of each espresso.

The Total Tamper is simple and quick to operate. Clear display icons allow easy access into each of the different modes for fast changes to the desired pressure.

If you require more information or have further questions not covered in these instructions, please contact Shenzhen Meshining Technology Co. Ltd or your local CINOART distributor (TopBarista360).

# Features

---

Touchpad Control Panel

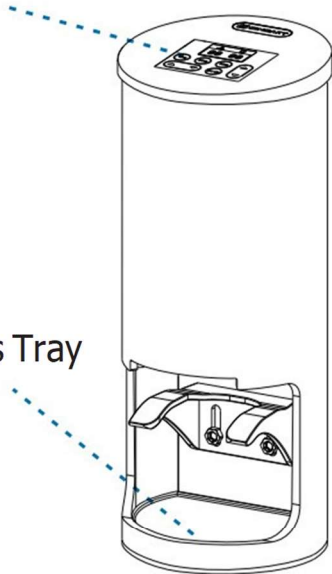

Silicone Grinds Tray

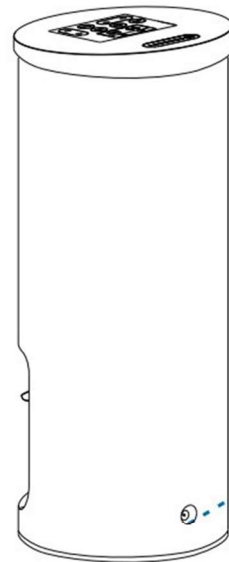

Power Plug

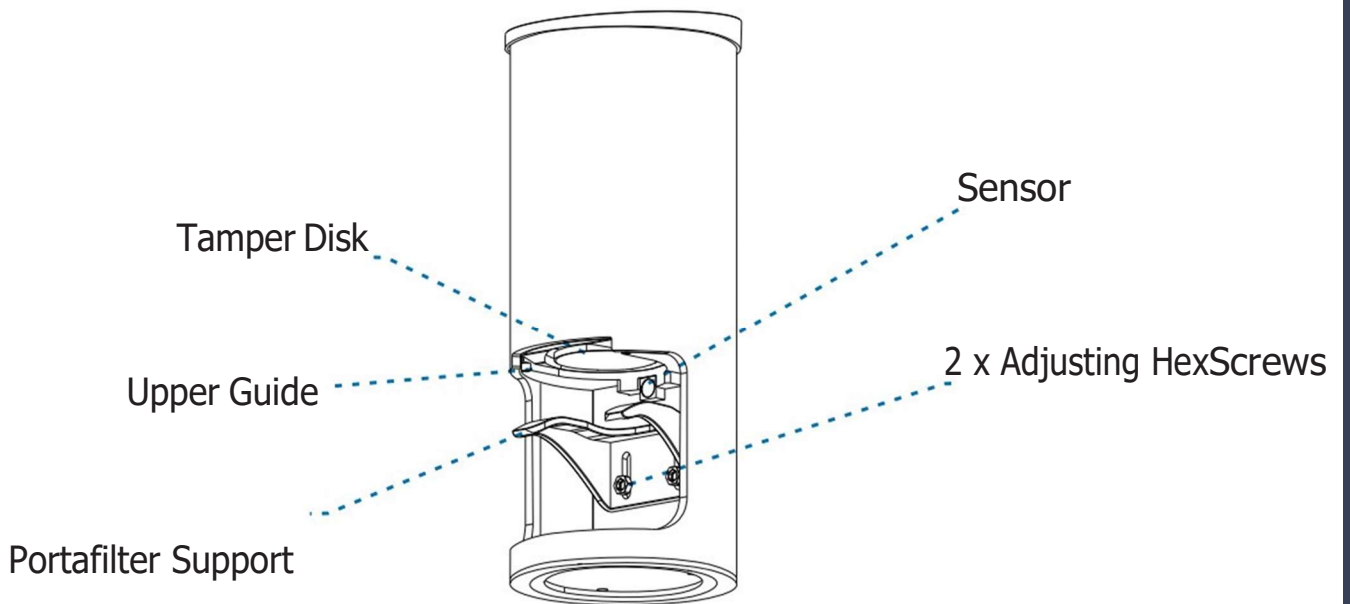

Tamper Disk

Upper Guide

Portafilter Support

Sensor

2 x Adjusting HexScrews

## Dimensions and Technical Specifications

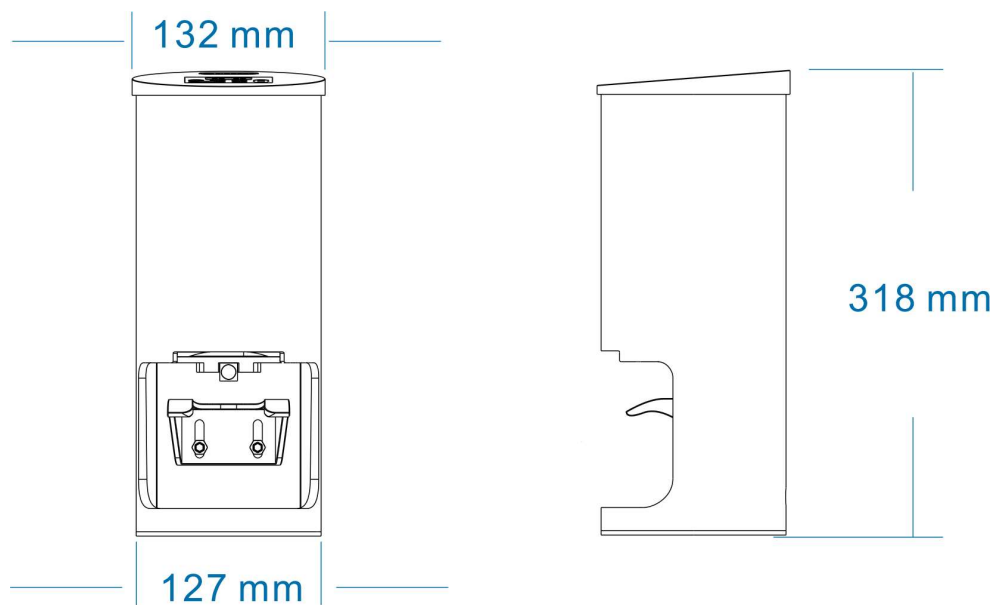

**Name**

**Automatic Tamper**

Model

Total Tamper

**Voltage In**

**110~240V 50/60Hz**

Voltage out

12V DC

**Weight**

**3.7 kg**

Tamper Diameter

51 to 58.3mm / Flat Base

**Pressure**

**From 2 kg to 38 kg**

Cycle Speed

1.2 seconds

**Multi Segment Tamping**

**1, 2 or 3 times**

## Set up and Portafilter Adjustment

The CINOART tamper is designed for easy adjustment to the Portafilter / Group Handle

1. Turn off the power by removing the power cord at the rear of the machine.
2. Turn the Total Tamper upside down on a smooth flat nonslip surface.
3. Loosen the 2 Hex Screws with the supplied Allen Key.
4. Place the Portafilter Levelling Guide tool on top of the Tamper Disk.
5. Place the Portafilter handle upside-down on the Levelling Guide, then adjust the Supporting fork down onto the underside of Portafilter handle.

Image - Steps 1, 2 y 3

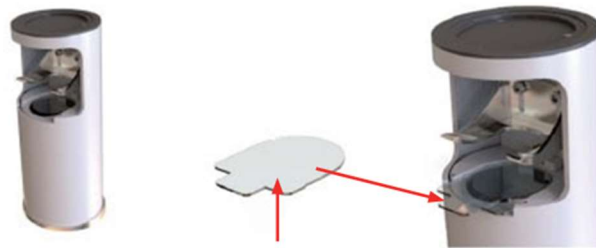

Portafilter Levelling Guide Tool

Images -Step 5



Images -Step 6: Re-tighten the 2 hex screws ensuring the supporting fork is level with the parallel indicator markings.



Images - Step 7: Remove the Levelling Guide Tool and return the Total Tamper to the upright position and reconnect the power.



## Environment

---

Place the Total Tamper on a flat, solid, and vibration-free surface. Do not operate the machine in wet or extreme temperature environments.

## Please check before use

---

1. Inspect the power cord to ensure there are no signs of damage or poor connection fittings.
2. Insert the power adaptor cord into the rear of the Total Tamper and then into the 10amp PowerPoint.

## Operation

---

1. Turn power on.
2. Ensure the digital display screen is illuminated and functional.
3. Set and program the desired tamp values via the touchpad.
4. The internal activation sensor will automatically detect the Portafilter handle.

## Pressure Adjustments

---

1. Quick access to preset pressures (10kg, 20kg, 30kg)
2. Precise +/- 1kg Up or Down increments to achieve desired pressure.
3. Quick Press and Hold the (\*) button to save the programmed values.
4. Multi Tamping Feature for 1, 2, 3 cycles



## Clean Mode

---

Performing a clean of the Tamper Disk can be done anytime during service and should be performed as a daily cleaning routine to brush off the residual build up of coffee fines and oils to help ensure clean tamping for best flavour and espresso quality.

Follow these steps:

- Press and hold the (\*) button for 5 seconds to access the Cleaning Mode.
- Clean the Tamper disk with a brush. Do not clean it with your fingers.
- Press and hold the (\*) button for 5 seconds to return it up into its original position.

*Note \*Cleaning Mode also allows the access needed to change the Tamper Disk to a different diameter to suit other espresso machine brands. Your local distributor will stock the different sizes.*



Press and hold to enter Cleaning Mode

## Common Errors

---

Issues	Potential Reasons	Potential Solution
Coffee fines and oils sticking to the tamper head	Tamper disk is wet, or has not been cleaned regularly causing further build up	Perform the cleaning mode outlined in Point 6. In this user guide
Machine not working / No illumination of touchpad icons	Check power cord and power adaptor	Check connection between wall Power Point and Transformer Adaptor and check connection from Transformer Adaptor into the rear of the machine
Coffee bed is uneven	Portafilter support fork is not level	Perform Portafilter Support alignment in Point 1. In this user guide
Tamper Disk does not fully extend	Cleaning Mode is on or the Portafilter support is not level	Cancel the Cleaning Mode or perform Portafilter realignment in Point 1. in this user guide

*Note \* If issues persist please contact your supplier for after sales service and technical support.*

## Technical Service and Support

---

- When or if you require after-sales service, please turn the power off, clean the machine, and call your place of purchase.
- Any service or repair should be carried out by an authorized service dealer.
- Do not attempt to repair it yourself in case of electrical fault.

## Spare Parts

---

Please contact TopBarista360 if you require a different diameter Tamper Disk for your espresso machine brand to the standard 58.3mm Portafilter basket.

All Spare Parts in general can be ordered from your supplier / distributor. Do not attempt to repair it yourself in case of electrical fault.

## Warranty

---

1. The warranty period is for one year from the date of purchase.
2. CinoArt warranties any defective or faulty components within the first 12 months from the date of purchase. Fair and reasonable use under normal wear and tear environment conditions will always be considered.
3. The warranty conditions do not cover damages caused by incorrect installation improper use, improper cleaning and maintenance.
4. Warranty does not cover damage caused from using non-genuine replacement parts.
5. Warranty does not cover general maintenance and or labour costs associated with replacement spare parts.





**TOP  
BARISTA 360**

[info@topbarista.com](mailto:info@topbarista.com)

[www.topbarista360.com](http://www.topbarista360.com)

Mobile Phone: +34 613 67 67 77

